

# COMPACT

CIAM

Bar H750



## H750 Refrigerated / Bar Counters

Monolithic AISI 304 stainless steel module | rounded internal edges | insulation with ecological water-based polyurethane | insulated cap | bottom shelf and intermediate shelf in plastic coated steel wire | polished stainless steel doors with micro hinges and gaskets with magnetic closure | 100 mm frame support for versions with an external condensing unit and 250/350 mm frame support for those with built-in condensing unit | ventilated refrigeration | system with R452a gas and natural defrosting for versions with remote condensing unit | removable condenser dust filter for modules with built-in condensing unit | condensation drainage directly into the base of counter | electronic touch control unit | stainless steel plinth with height-adjustable feet



 +34/+46 °



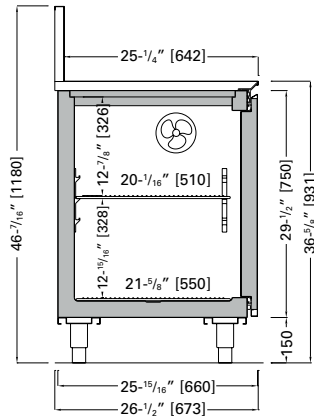

## Technical



- Ventilated
- Automatic / Hot Gas
- R452a
- N.4 / R.H. 55% / 75°F
- 1 / Hermetic
- 120 V / 1 ph / 60 Hz
- +34/+46 °F

## Data Sheet

\*Measurements are subject to revisions/updates, please refer to manufacturer's drawings at order confirmation



\*Crated dimensions and weight

Model Code	Dimensions LxDxH - Inches	Weight Lbs	Max Pwr. Consumption W / A	Avg Operating Consumption KW/H	Cooling Power/Expansion BTU / °F	GAS Type
CBBPVF1P6H7TI	29-1/2 X 26-1/2 X 46-7/16	132.28	220/1,6	0,13	511.82 / 3.2	R452a
	36-5/8 X 33-9/16 X 57-7/8	275.58 Cabinet + Crate				
CBBPVF2P6H7TI	49-1/4 X 26-1/2 X 46-7/16	176.37	220/1,7	0,14	989.52 / 3.2	R452a
	56-5/16 X 33-9/16 X 57-7/8	374.78 Cabinet + Crate				
CBBPVF3P6H7TI	68-7/8 X 26-1/2 X 46-7/16	231.48	300/2,3	0,19	1,364.86 / 3.2	R452a
	75-15/16 X 33-9/16 X 57-7/8	507.06 Cabinet + Crate				

\*\*Cabinet height measurement includes Type C countertop backsplash; Cabinet height without backsplash is 36-5/8" tall.  
\*\*Overall length dimension may vary due to size of condensing unit tray. Please refer to manufacturer's drawings at order confirmation for final dimensions.

## Optionals:

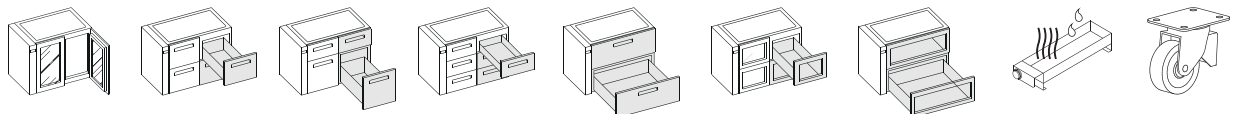

- SCGR01**  
Compact-Glass Doors
- CCCR06**  
Double-Drawers 1/2-1/2
- CCCR07**  
Double-Drawers 1/2-1/2
- CCCR08**  
Triple Drawers
- CCCR09**  
Double-Wide Drawers
- CCGR09**  
Glass Drawers 1/2-1/2
- CCGR10**  
Double-Wide Glass Drawers
- CSCR07**  
Heated Evaporation Pan
- CIM08**  
Casters