

# VERTIGO-2

## CHOCOLATE DISPLAY

Project:  
Quantity:

Item:



### Finish Options:

Okite- quartz based granite, RAL color system, ALPI wood laminates, Arpa laminates.



### Optional Features:

- Operator side night curtain
- Casters
- Remote condensing unit

### Standard Features:

- Fully illuminated shelves
- Electric defrost
- Digital control panel
- Tempered tilt down front glass
- Polished aluminum profiles
- Sliding plexi-glass doors
- LED lighting
- Humidity control accessory



# AG ADVANCED GOURMET

EQUIPMENT & DESIGN

Street: 5C Wendy Ct, Greensboro, NC 27409  
Mail: PO Box 18542, Greensboro, NC 27419  
P: 336.856.2919 F: 336.217.8838

Sales@AdvancedGourmet.com  
AdvancedGourmet.com  
PacojetUS.com AdvancedGourmetDisplays.com

# VERTIGO-2

## CHOCOLATE DISPLAY

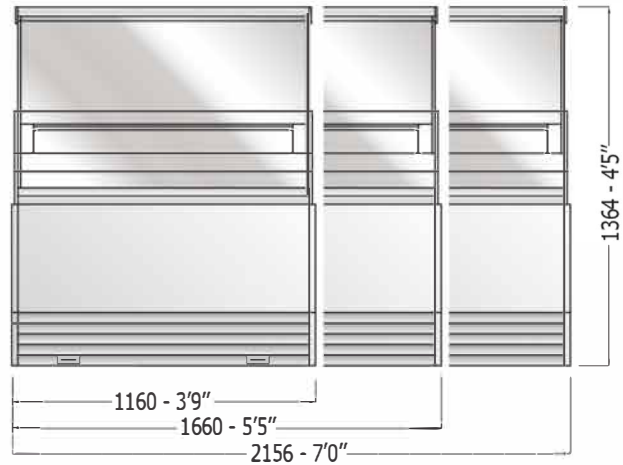
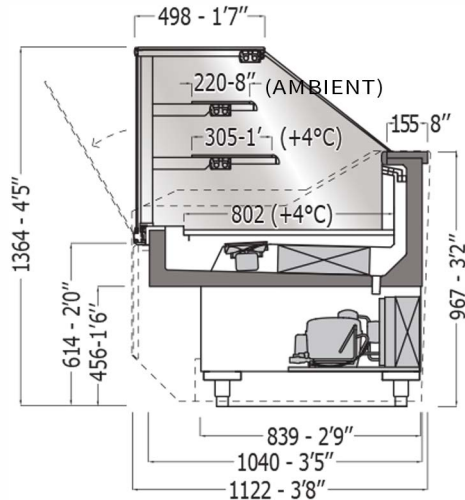

TECHNICAL FEATURE		VERSIONS				
		1110	1610	2106	30° Open Corner	30° Closed Corner
External dimensions (L-D-H)	inches mm	43 <sup>2</sup> / <sub>3</sub> " - 44 <sup>1</sup> / <sub>8</sub> " - 53 <sup>2</sup> / <sub>3</sub> " 1160-1122-1364	65 <sup>1</sup> / <sub>3</sub> " - 44 <sup>1</sup> / <sub>8</sub> " - 53 <sup>2</sup> / <sub>3</sub> " 1660-1122-1364	84 <sup>7</sup> / <sub>8</sub> " - 44 <sup>1</sup> / <sub>8</sub> " - 53 <sup>2</sup> / <sub>3</sub> " 2156-1122-1364	62" - 44 <sup>1</sup> / <sub>8</sub> " - 53 <sup>2</sup> / <sub>3</sub> " 1574-1122-1364	62" - 44 <sup>1</sup> / <sub>8</sub> " - 53 <sup>2</sup> / <sub>3</sub> " 1574-1122-1364
Crated dimensions (L-D-H)	inches mm	52" - 52" - 63 <sup>3</sup> / <sub>4</sub> " 1320-1320-1620	71 <sup>5</sup> / <sub>8</sub> " - 52" - 63 <sup>3</sup> / <sub>4</sub> " 1820-1320-1620	91 <sup>1</sup> / <sub>3</sub> " - 52" - 63 <sup>3</sup> / <sub>4</sub> " 2320-1320-1620	70 <sup>7</sup> / <sub>8</sub> " - 52" - 63 <sup>3</sup> / <sub>4</sub> " 1800-1320-1620	70 <sup>7</sup> / <sub>8</sub> " - 52" - 63 <sup>3</sup> / <sub>4</sub> " 1800-1320-1620
Refrigeration	Type	Fan Ventilated	Fan Ventilated	Fan Ventilated	Fan Ventilated	Fan Ventilated
Refrigerated display area	Type	Deck / Shelves	Deck / Shelves	Deck / Shelves	Deck / Shelves	Deck / Shelves
Operating temperature	°C / °F	+4 / 39.2	+4 / 39.2	+4 / 39.2	+4 / 39.2	+4 / 39.2
Compressor	nr. / Type	1 / hermetic	1 / hermetic	1 / hermetic	1 / hermetic	1 / hermetic
Cooling power *	(W)	820	1030	1290	1100	1010
Electric supply	(V/ph/Hz)	220/1/60 (USA)	220/1/60 (USA)	220/1/60 (USA)	220/1/60 (USA)	220/1/60 (USA)
Power consumption	(W/A)	1085/8,2	1190/8,0	1490/9,0	1170/8,0	1140/8,0
Defrost	Mode / type	electric	electric	electric	electric	electric
Climatic class	N°°C/F°/H.R.	4+/35/95/70%	4+/35/95/70%	4+/35/95/70%	4+/35/95/70%	4+/35/95/70%
Refrigerant Gas	Type	R404A	R404A	R404A	R404A	R404A
Net weight	Kg / Lb	205 / 650	275 / 606	340 / 749	250 / 551	250 / 551
Crated weight	Kg / Lb	315 / 694	425 / 936	530 / 1168	400 / 881	400 / 881

\*Installation of electrical to be completed by contracted electrician

\*Machines do not come with cord or plug and require proper connection within the guidelines of local area

\*Actual finished dimensioned to be taken only from CAD drawings provided by Advanced Gourmet

\*Contact Advanced Gourmet for CAD files

**AG** ADVANCED GOURMET  
EQUIPMENT & DESIGN

United States Importer of:

