

# TORTUGA

## DRY-WARM DISPLAY

Project:  
Quantity:

Item:



### Finish Options:

Okite- quartz based granite, RAL color system, ALPI wood laminates, Arpa laminates.



### Optional Features:

- Available with 1, 2, & 3 shelving options
- Casters
- Remote compressor

### Standard Features:

- Ventilated heating system
- LED lighting system
- Double glazed walls
- Sliding doors on the operators side
- Digital temperature control



# AG ADVANCED GOURMET

EQUIPMENT & DESIGN

Street: 5C Wendy Ct, Greensboro, NC 27409  
Mail: PO Box 18542, Greensboro, NC 27419  
P: 336.856.2919 F: 336.217.8838

Sales@AdvancedGourmet.com  
AdvancedGourmet.com  
PacojetUS.com AdvancedGourmetDisplays.com

# TORTUGA

## DRY-WARM DISPLAY

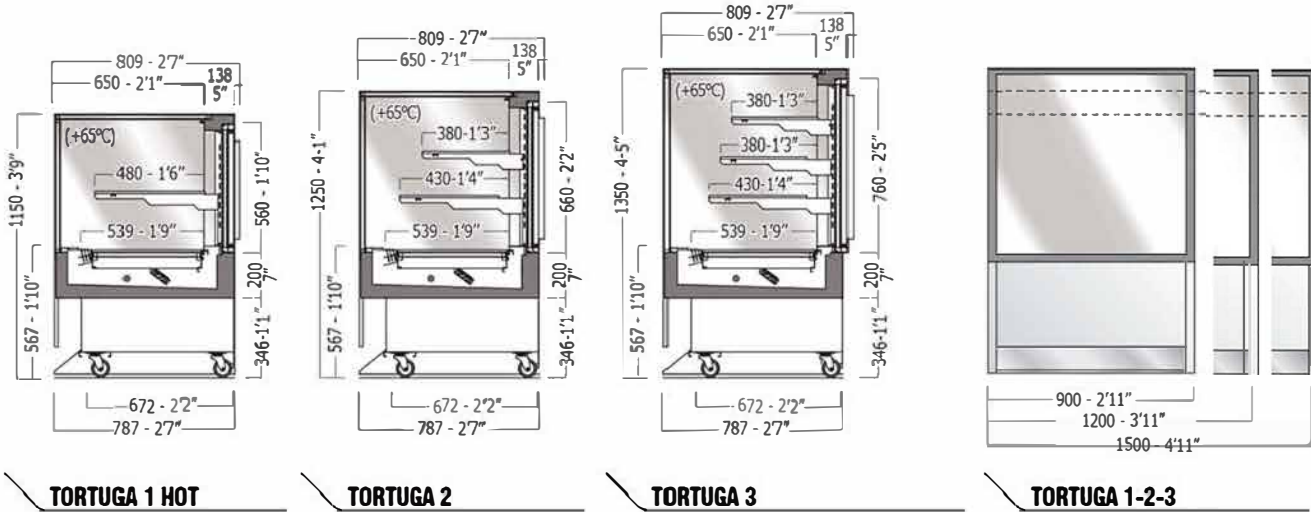

**TORTUGA 1 HOT**

**TORTUGA 2**

**TORTUGA 3**

**TORTUGA 1-2-3**

TECHNICAL FEATURE		TORTUGA 1			TORTUGA 2			TORTUGA 3		
		0900	1200	1500	0900	1200	1500	0900	1200	1500
External dimensions (L-D-H)	inches mm	35 1/4 - 31 1/2 - 45 1/4 900-809-1150	47 1/4 - 31 1/2 - 45 1/4 1200-809-1150	59 - 31 1/2 - 45 1/4 1500-809-1150	35 1/4 - 31 1/2 - 49 1/4 900-809-1250	47 1/4 - 31 1/2 - 49 1/4 1200-809-1250	59 - 31 1/2 - 49 1/4 1500-809-1250	35 1/4 - 31 1/2 - 53 1/4 900-809-1350	47 1/4 - 31 1/2 - 53 1/4 1200-809-1350	59 - 31 1/2 - 53 1/4 1500-809-1350
Crated dimensions (L-D-H)	inches mm	43 3/8 - 39 3/8 - 55 1/2 1100-1000-1400	55 1/2 - 39 3/8 - 55 1/2 1400-1000-1400	66 7/8 - 39 3/8 - 55 1/2 1700-1000-1400	43 3/8 - 39 3/8 - 59 1100-1000-1500	55 1/2 - 39 3/8 - 59 1400-1000-1500	66 7/8 - 39 3/8 - 59 1700-1000-1500	43 3/8 - 39 3/8 - 63 1100-1000-1600	55 1/2 - 39 3/8 - 63 1400-1000-1600	66 7/8 - 39 3/8 - 63 1700-1000-1600
Heating system	Type	Ventilated	Ventilated	Ventilated	Ventilated	Ventilated	Ventilated	Ventilated	Ventilated	Ventilated
Heated display area	Type	Deck / Shelves	Deck / Shelves	Deck / Shelves	Deck / Shelves	Deck / Shelves	Deck / Shelves	Deck / Shelves	Deck / Shelves	Deck / Shelves
Operating temp.	°C / °F	+65 / 149	+65 / 149	+65 / 149	+65 / 149	+65 / 149	+65 / 149	+65 / 149	+65 / 149	+65 / 149
Electric supply	(V/ph/Hz)	230/1/50 (UE) 220/1/60 (USA)	230/1/50 (UE) 220/1/60 (USA)	230/1/50 (UE) 220/1/60 (USA)	230/1/50 (UE) 220/1/60 (USA)	230/1/50 (UE) 220/1/60 (USA)	230/1/50 (UE) 220/1/60 (USA)	230/1/50 (UE) 220/1/60 (USA)	230/1/50 (UE) 220/1/60 (USA)	230/1/50 (UE) 220/1/60 (USA)
Power consumption	(W/A)	1800 / 7,0	2300 / 9,0	2600 / 11,0	1900 / 8,0	2400 / 10,5	2800 / 8,6	2600 / 8,6	2500 / 11,0	3000 / 13,0
Net weight	Kg / Lb	100 / 220	130 / 286	160 / 352	115 / 253	150 / 330	180 / 396	130 / 286	170 / 374	200 / 440
Crated weight	Kg / Lb	160 / 352	210 / 462	225 / 496	185 / 407	235 / 518	280 / 617	202 / 445	260 / 454	310 / 683

- \*Installation of electrical to be completed by contracted electrician
- \*Machines do not come with cord or plug and require proper connection within the guidelines of local area
- \*Actual finished dimensioned to be taken only from CAD drawings provided by Advanced Gourmet
- \*Contact Advanced Gourmet for CAD files

**AG** ADVANCED GOURMET  
EQUIPMENT & DESIGN

United States Importer of:

