

cattabriga PSK-KEL

Model: 65

Project:

Quantity:

Item:



Inverter



Bain Marie System

Standard Features:

- Lightweight agitator
- Adjustable speed
- Indirect “bain marie” heat source
- Preservation of flavors
- Flexibility to choose the ideal temperature for each type of mix



940 Calle Amanecer, Suite G
San Clemente, CA 92673

P: 877.969.4352
F: 949.212.9753



Info@EquipmentAndConcepts.com
EquipmentAndConcepts.com

cattabriga PSK-KEL

Model: 65

Project:

Quantity:

Item:

Plan View

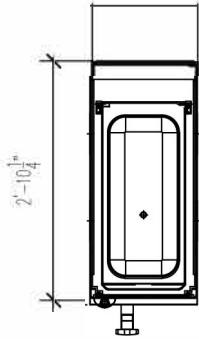

Rear Detail

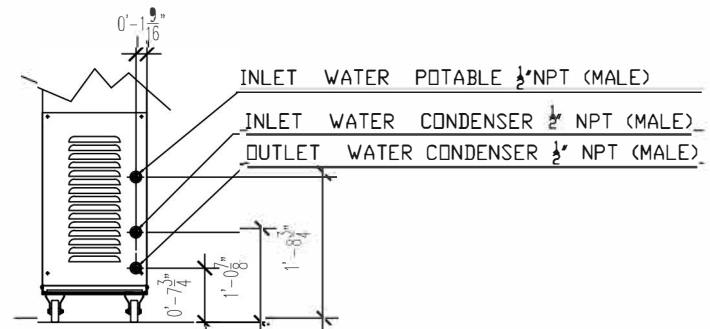

0'-6" MINIMUM SIDE CLEARANCE

Front Elevation

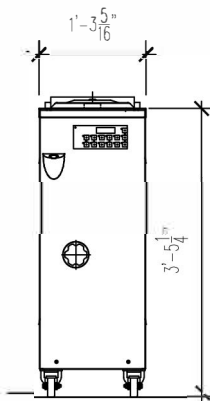

Side View

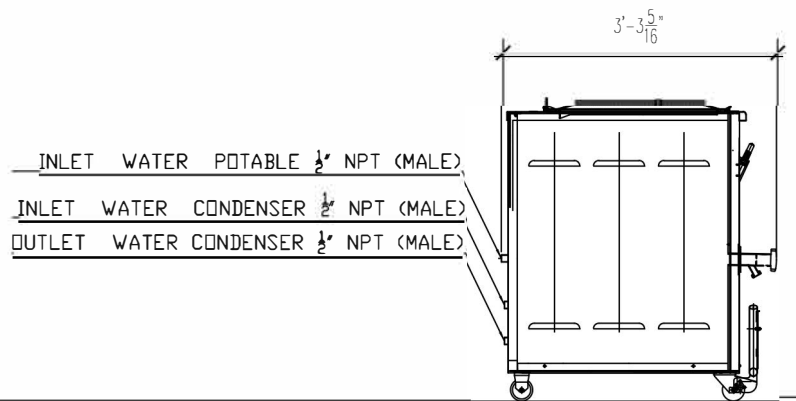

Technical Specifications: PSK-KEL 65

Capacity Min/Max: 20L/60L

Electrical Supply (V/Ph/Hz): 208-230V/3Ph/60Hz.

Min Amp/Max Fuse: 18/25

Dimensions (WxDxH): 15.4"x34.6"x42.1"

Net Wt. Kg/Lb: 204Kg./450Lb.

- *Installation of electrical and plumbing to be completed by contracted electrician
- *Machines do not come with cord or plug and require proper connection within the guidelines of local area
- *Continuing research results in steady improvements; **therefore, these specifications are subject to change without notice**

