

# COLDELITE Compacta VariO

Model: Pro 8

Project:  
Quantity:  
Item:



Inverter



Multifunction Beater



Double Exit Top Door



Cortex Board



High Temperature Heating



Eco Friendly Heating

#### Standard Features:

- all in one system with heating and freezing
- pre-programmed recipes and operator input
- precise temperature control for heating, cooling, and freezing
- small footprint
- adjustable production- as little as 15% of maximum capacity
- reach up to 105°C



# AG

# ADVANCED GOURMET EQUIPMENT & DESIGN

Street: 5C Wendy Ct, Greensboro, NC 27409  
Mail: PO Box 18542, Greensboro, NC 27419  
P: 336.856.2919 F: 336.217.8838

Sales@AdvancedGourmet.com  
AdvancedGourmet.com



# Compacta VariO

Model: Pro 8

Project:

Quantity:

Item:

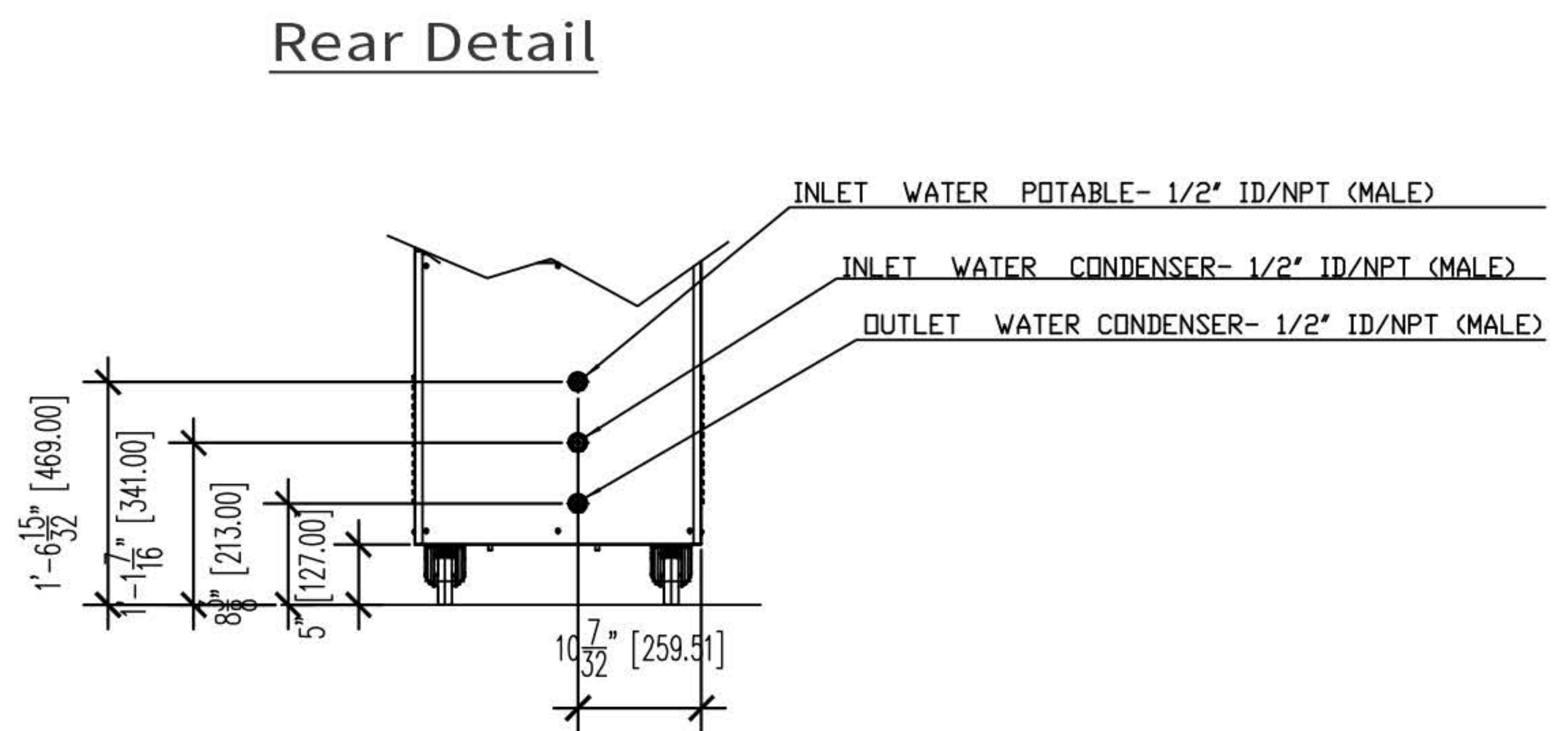
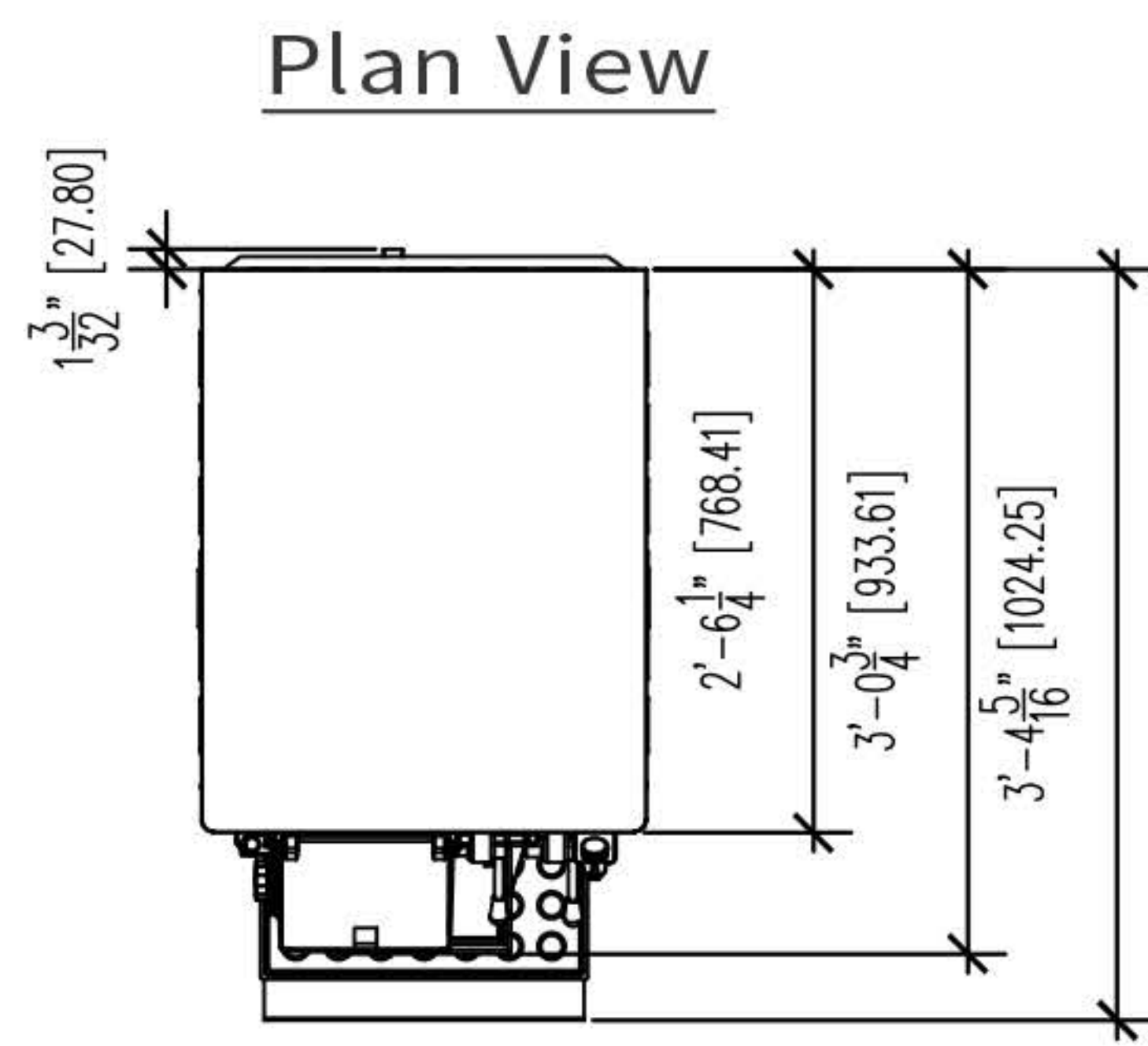

**\*0'-6" MINIMUM SIDE CLEARANCE\***

Front Elevation

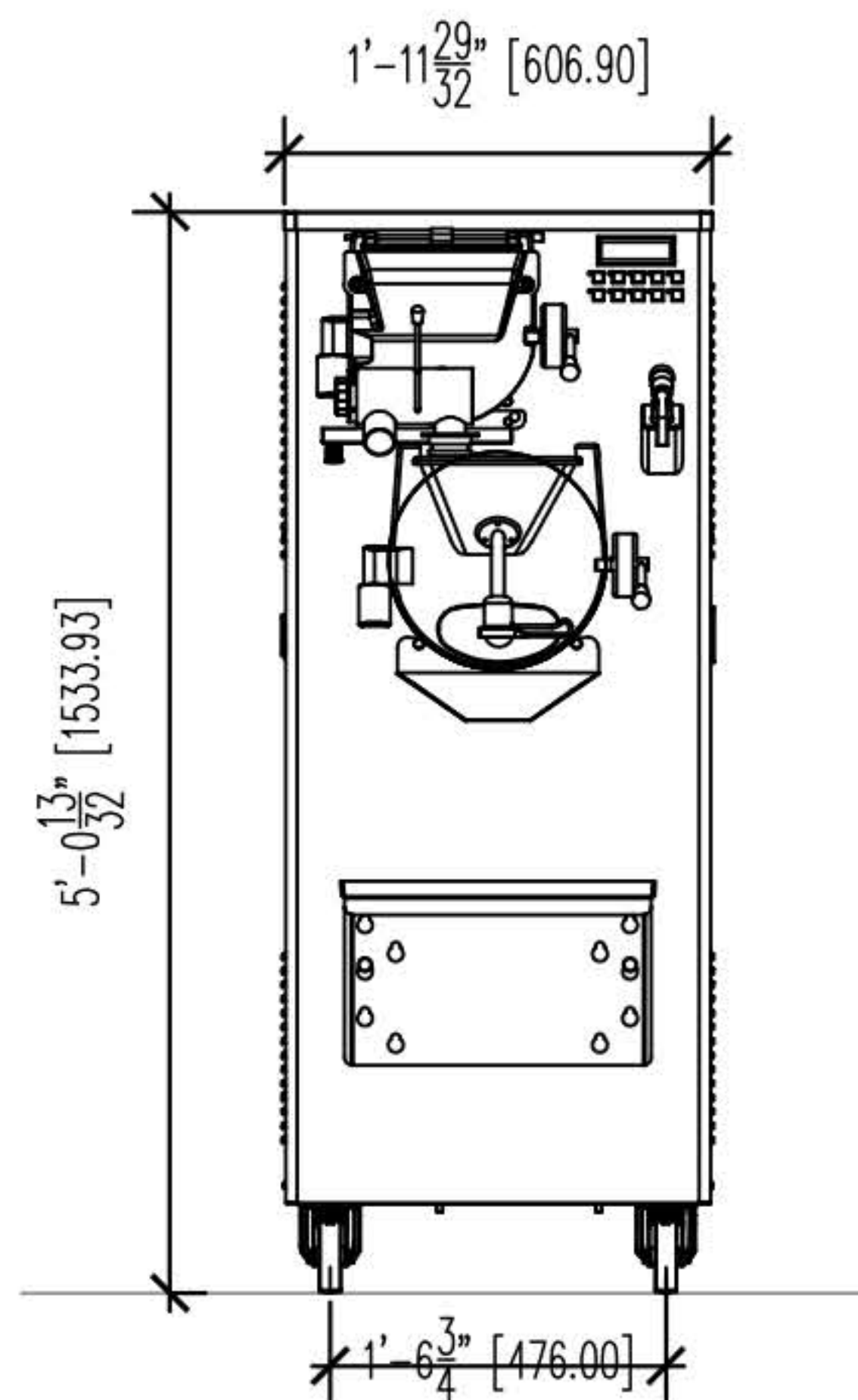

Side View

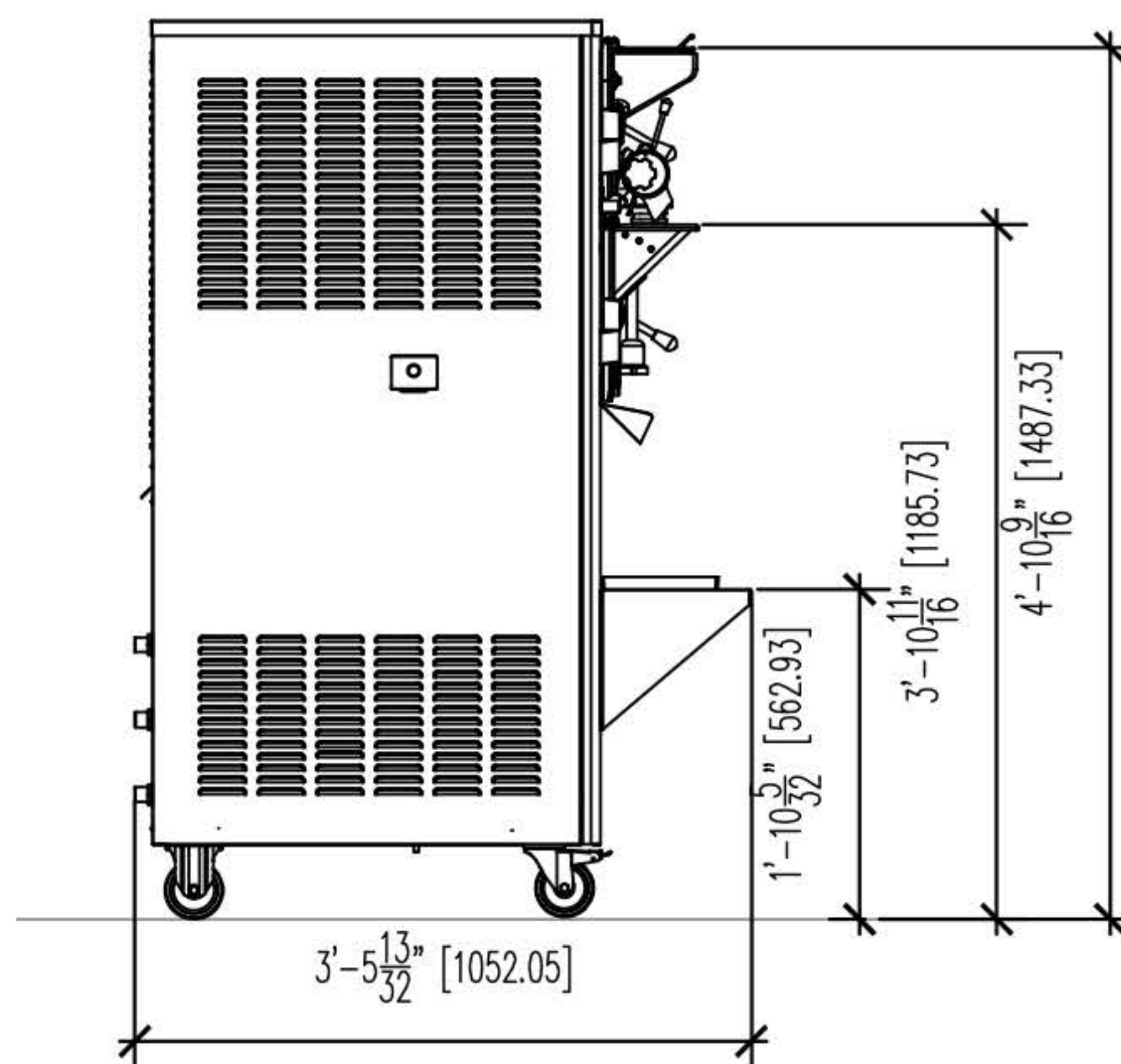

## Technical Specifications: Compacta Vario- Pro 8

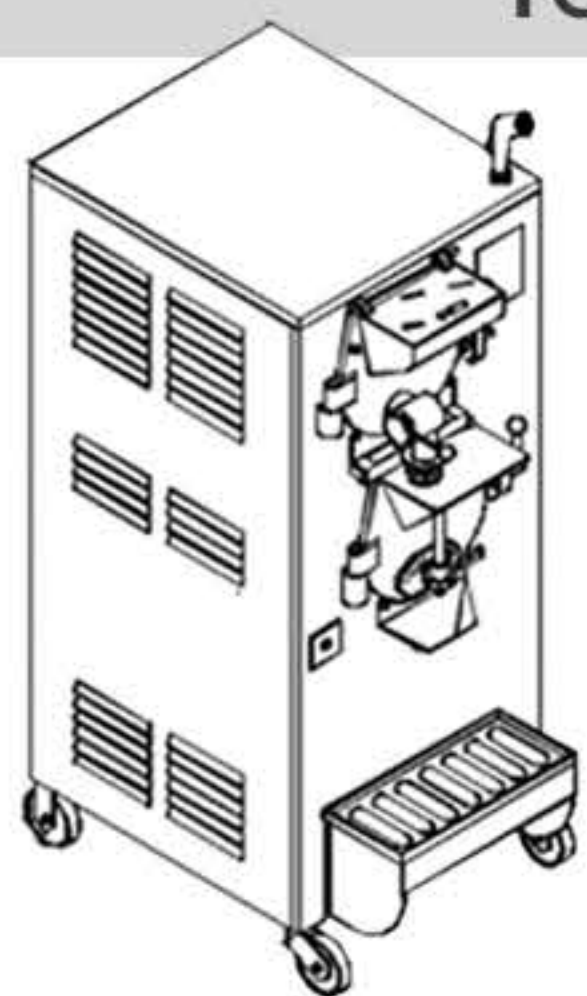

Quantity per Batch Min/Max: 1.5Lt./8Lt.

Electrical Supply (V/Ph/Hz.): 208-230V/3Ph/60Hz.

Min Amp/Max Fuse: 50/50

Dimensions (WxDxH): 23.62"x30.32"x60.24"

Net Wt. Kg./Lb.: 290Kg./638Lb.

\*Installation of electrical and plumbing to be completed by contracted electrician

\*Machines do not come with cord or plug and require proper connection within the guidelines of local area

\*Continuing research results in steady improvements; therefore, **these specifications are subject to change without notice**

