

Project:  
Quantity:  
Item:



Inverter



"Elite" Stainless Steel Beater



Dialog System



TC Board



Heating Plates



Double Exit Top Door

Standard Features:

- 11 preset programs
- customize and store batch freezing cycles
- varying rotation speed of beater
- small footprint
- heat, mix, and freeze, all in one
- direct transfer from top to bottom chamber





# Compacta VariO

Model: Elite 8

Project:

Quantity:

Item:

Plan View

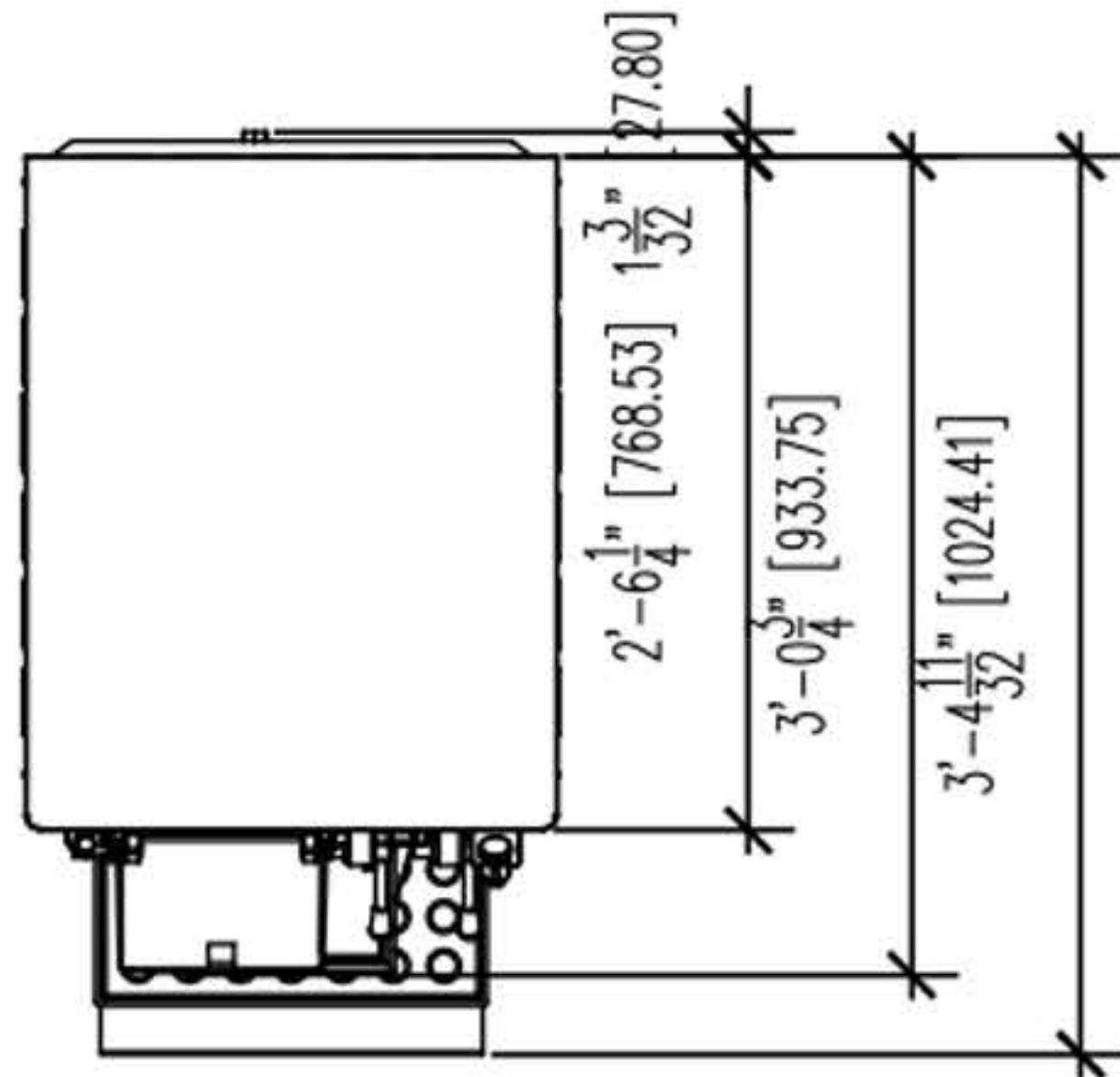

Front Elevation

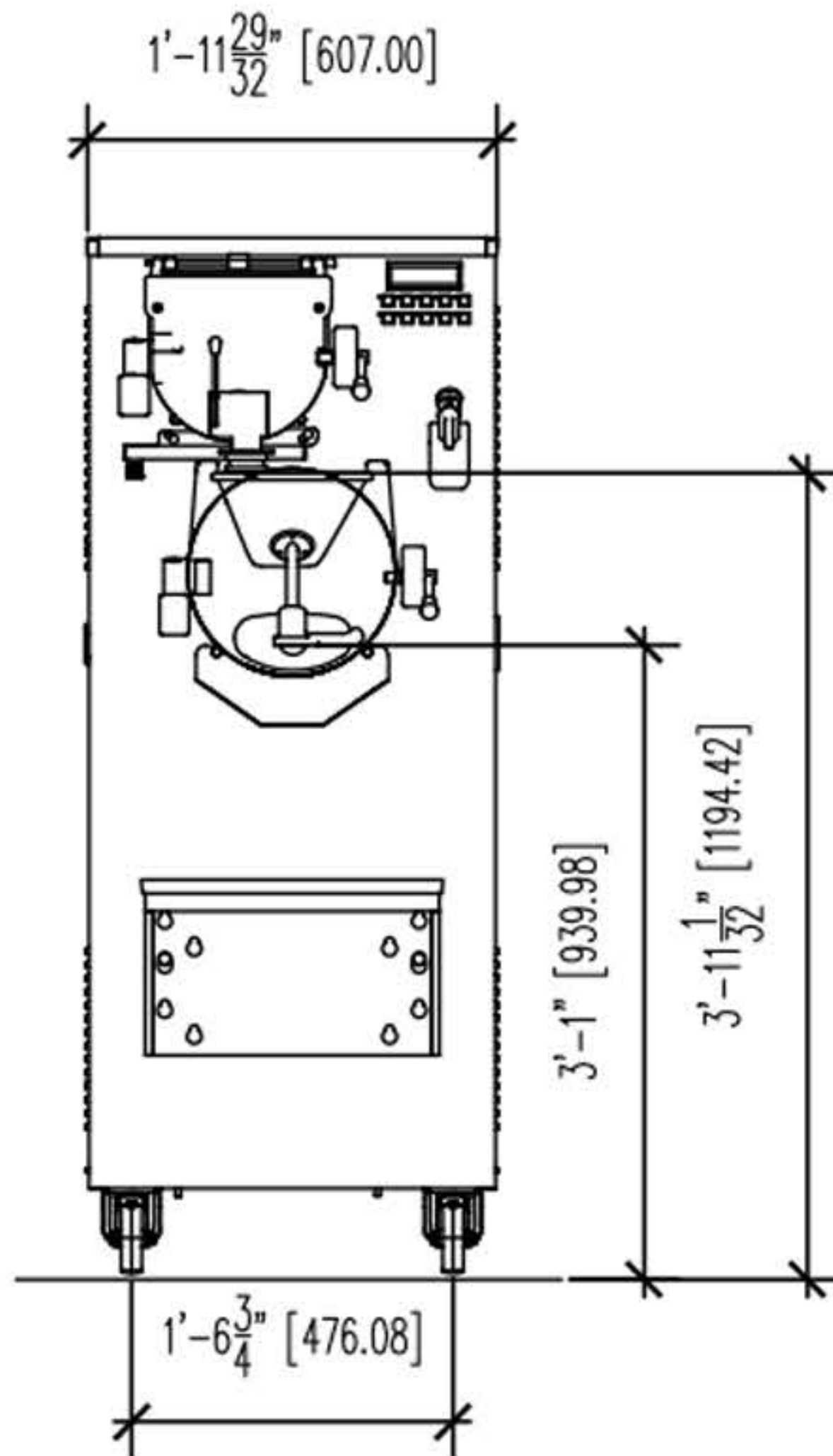

Rear Detail

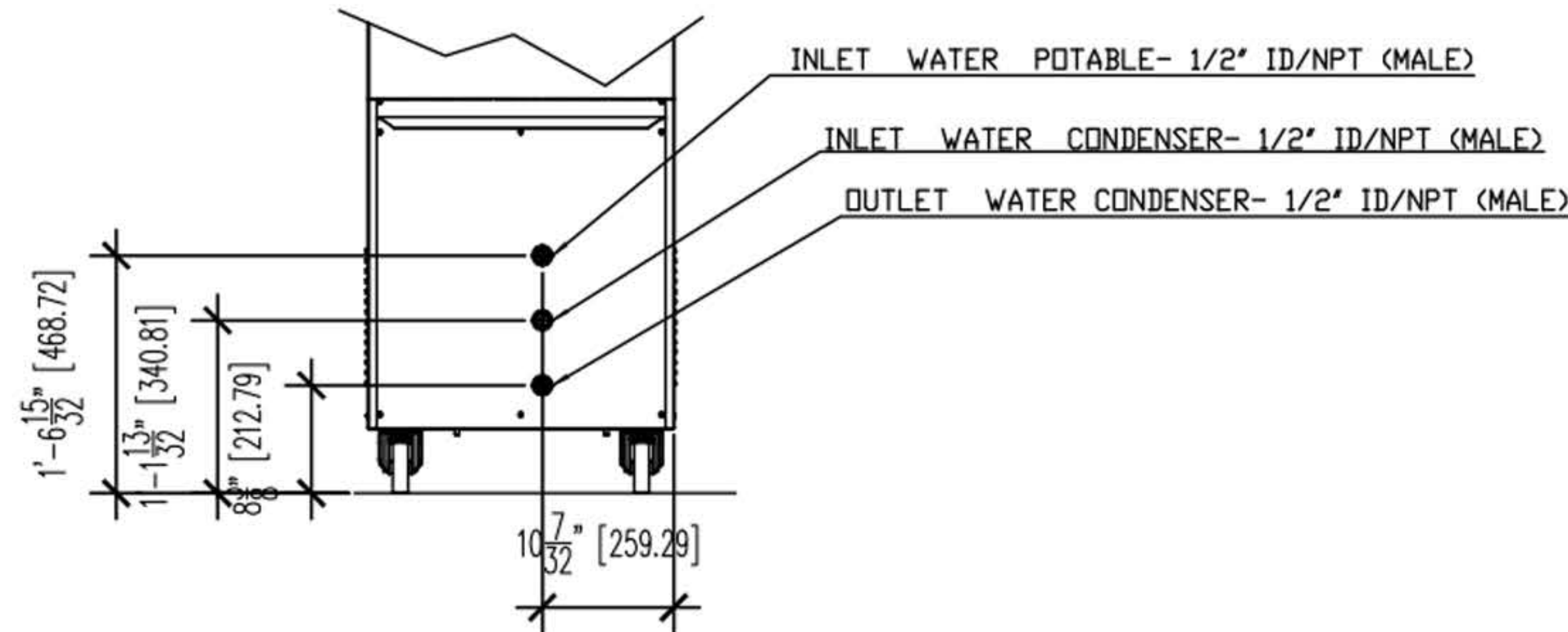

Side View

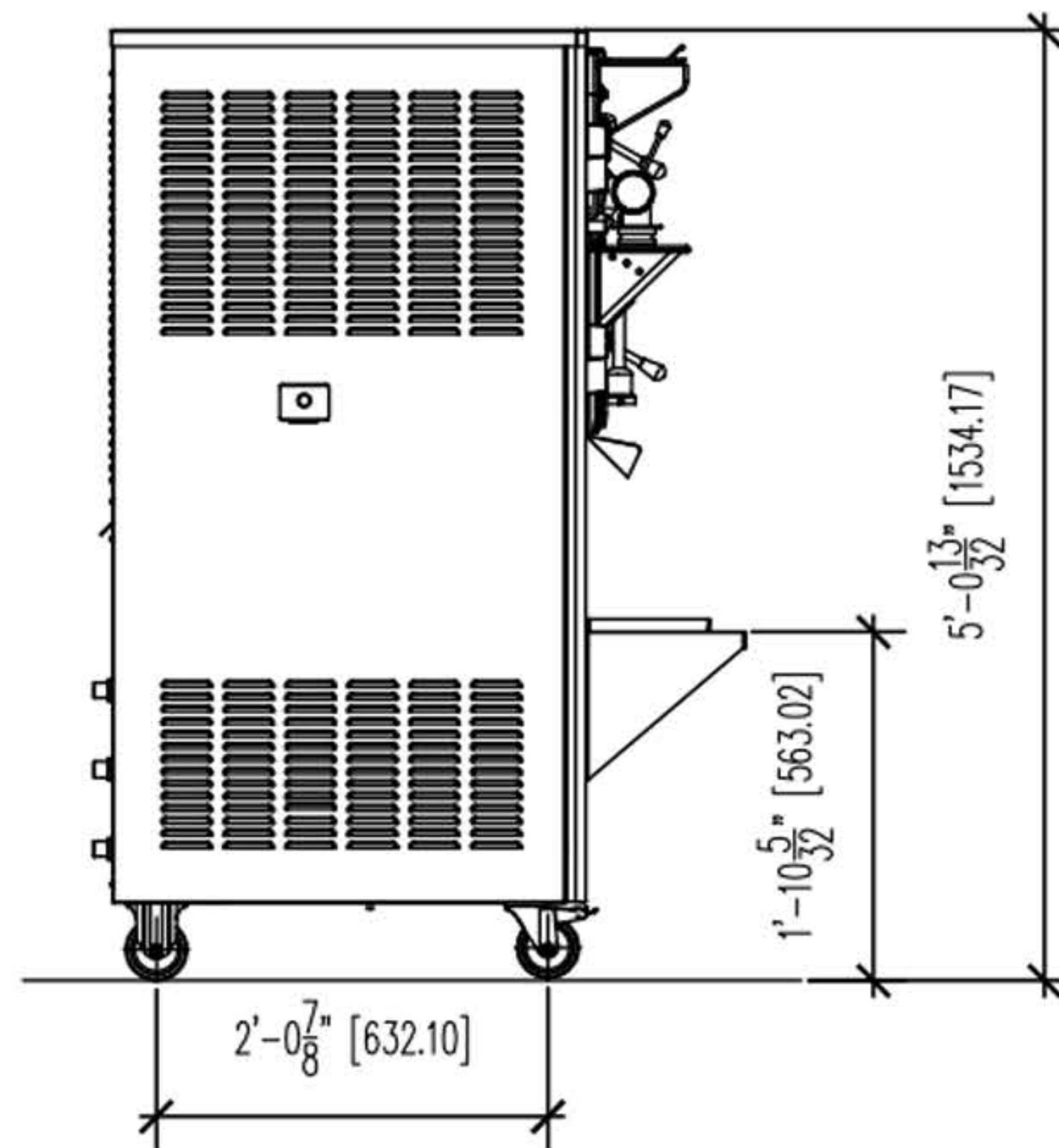

**\*0'-6" MINIMUM SIDE CLEARANCE\***

## Technical Specifications: Compacta Vario- Elite 8

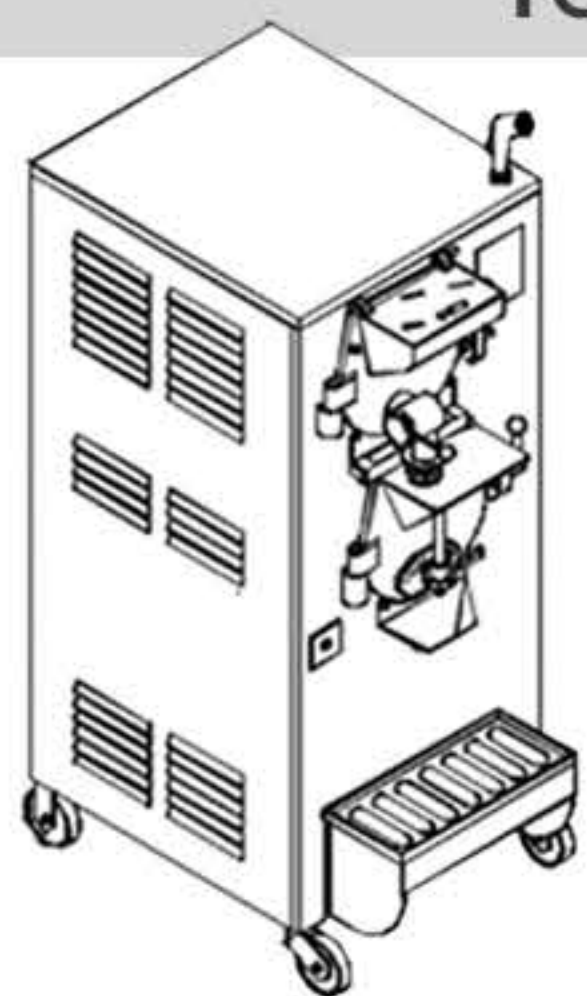

Quantity per Batch Min/Max: 2Lt./11Lt.

Electrical Supply (V/Ph/Hz.): 208-230V/3Ph/60Hz.

Min Amp./Max Fuse: 50/50

Dimensions (WxDxH): 23.62"x30.31"x60.24"

Net Wt. Kg./Lb.: 290Kg./638Lb.

\*Installation of electrical and plumbing to be completed by contracted electrician

\*Machines do not come with cord or plug and require proper connection within the guidelines of local area

\*Continuing research results in steady improvements; therefore, **these specifications are subject to change without notice**