

# AMIKA PASTRY DISPLAY

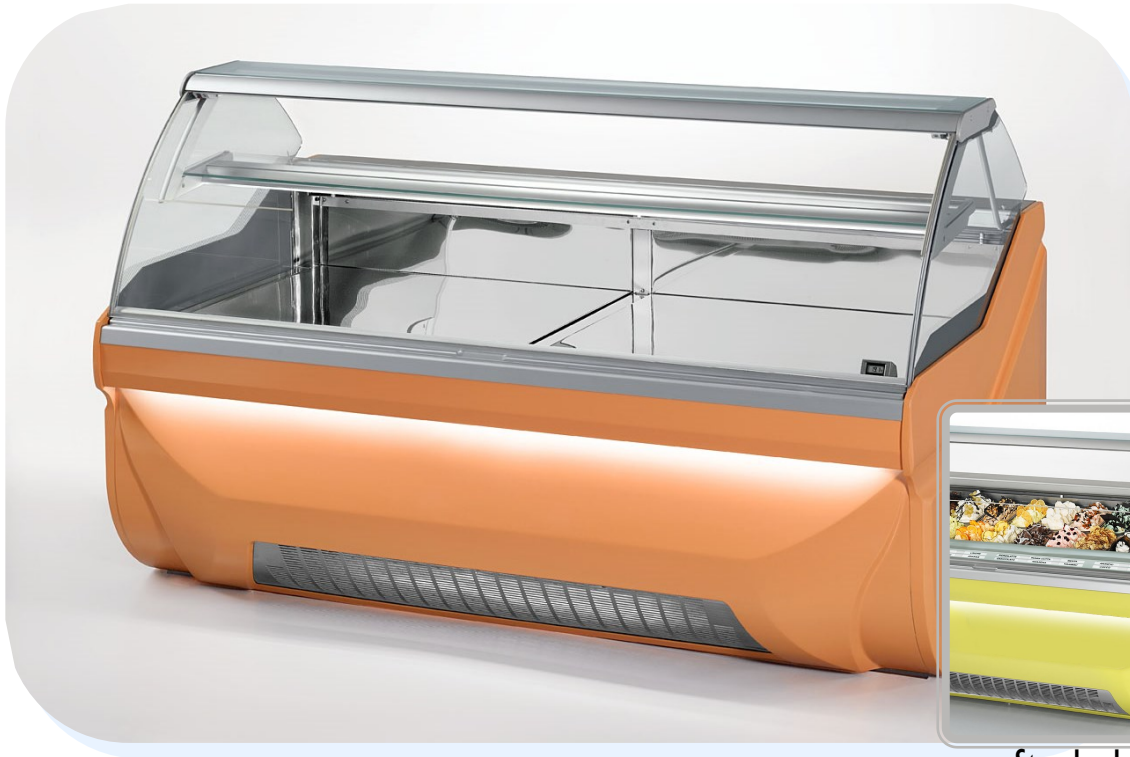

Standard Amika



Custom Amika

## Colors:

RAL color choice, Okite-Quartz finish, ALPI wood laminate, or design collection finish type



OKITE



ALPI

## Key Features:

- ◇ High Performance: Double evaporator/automatic reverse cycle defrost/Easy open front glass with piston assisted lift-up opening system
- ◇ Visibility: Extraordinary enhancement of displayed products
- ◇ Customizable: Wide assortment of finish options and cladding styles
- ◇ Storage in display

Tubular structure in painted s/s. Molded heat insulated tank with rounded internal edges, coated by AISI 304 s/s. Pre-arrangement for 5.2L pans (dim: 360x165x120h (not included)) with storage. S/S flavor labels with back lighting, fan ventilated refrigeration system with double finned evaporator, automatic reverse defrost cycle, digital control panel, brushed s/s working top, tempered lift-up front glass with pyrolytic anti-fog treatment, glass sides with aesthetic anti-fog warming system, silver aluminum profiles, and operator side closure with self rolling curtain.



# AMIKA PASTRY DISPLAY

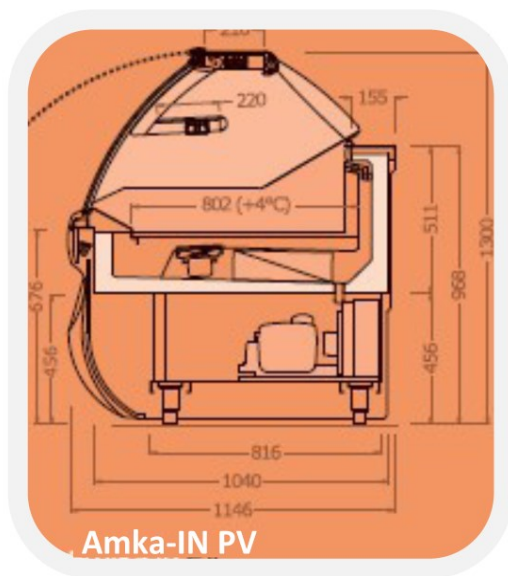

Amka-IN PV

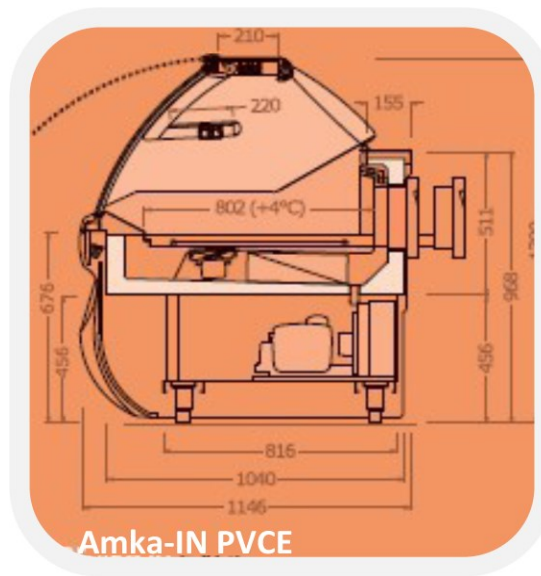

Amka-IN PVCE



Storage Drawers Option



Easy Open Glass

TECHNICAL FEATURES		VERSION					
		1110	1610	2106	2106 Dual Temp.	30° open corner	30° closed corner
Refrigeration	Type	Fan Ventilated	Fan Ventilated	Fan Ventilated	Fan Ventilated	Fan Ventilated	Fan Ventilated
Operating Temperature	°C/°F	+4/39.2	+4/39.2	+4/39.2	+4/39.2	+4/39.2	+4/39.2
Compressor	No./Type	1/hermetic	1/hermetic	1/hermetic	1/hermetic	1/hermetic	1/hermetic
Electric Supply	V/Ph/Hz	120/1/60	120/1/60	120/1/60	120/1/60	120/1/60	120/1/60
Climatic Class	N°/C/F°/H.R.	4+/35/95/70%	4+/35/95/70%	4+/35/95/70%	4+/35/95/70%	4+/35/95/70%	4+/35/95/70%
Refrigerant Gas	Type	R404A	R404A	R404A	R404A	R404A	R404A

\*Note: Actual finished dimensions to be taken only from CAD drawings provided by Advanced Gourmet\*



**AG** ADVANCED GOURMET  
EQUIPMENT & DESIGN  
O:(336) 856-2919 F:(336) 217-8838  
www.AdvancedGourmet.com  
sales@AdvancedGourmet.com  
The United States Importer of:  
**CIAM**